

320NX

Single-frequency CW UV laser



The 320NX laser platform offers DPSS CW single-frequency operation within the UV wavelength range, with up to 200 mW power, outstanding beam characteristics, high output stability, extremely low noise, small footprint, and a versatile software package – making it suitable for a wide range of applications and system integration.

KEY FEATURES



Ultra-narrow Linewidth
No chromatic dispersion



High Power Stability
Consistent illumination



High Spectral Stability
Consistent measurement



Integrated Design
Easy to install

APPLICATIONS

Semiconductor Inspection - Wafer Fabrication - Lithography - Confocal Microscopy - Raman Spectroscopy - Biomedical/Bioengineering - Flow Cytometry - Fluorescence - Disc Mastering - Diffraction Grating Mastering - High Precision Optics - and more.

Specifications

Output Beam Parameters:

Output Power	up to 200 mW
Wavelength	320 nm
Spectral Bandwidth	≤ 0.5 MHz
Spatial Mode	TEM ₀₀
Spectral Stability	± 1.0 pm (over 8 hour operation)
Coherence Length	> 100 m
Output Power Stability	≤ 2.0 % (over 8 hour operation)
Output Power Noise	≤ 0.1 % RMS (10 Hz – 10 MHz)
Beam Divergence	≤ 2.5 mrad, diffraction limited
Beam Diameter at Output Aperture	0.6 – 1.2 mm
Beam Pointing Stability	≤ 5 μrad/°C

Integration Features:

Plug-In USB Connectivity	Combined Heatsink
Versatile Control Software	Remote Diagnostic Support

Laser Head Dimensions:

L x W x H	240 x 150 x 100 mm
Beam Height	65 mm

Environmental Conditions:

Ambient Temperature Range	18 – 30 °C
Laser Head Interface Stability	± 1.5 °C
Storage	0 – 50 °C
Humidity	5 – 95 %, non-condensing
Laser Head	Hermetically sealed

Optional Accessories:

Heatsink	Fan-Assisted air-cooled or Water-Cooled with Thermoelectric Chiller
External Manual Power Control	0 – 100 %, continuous

Warranty:

12 Month Warranty	For laser head and controller
-------------------	-------------------------------

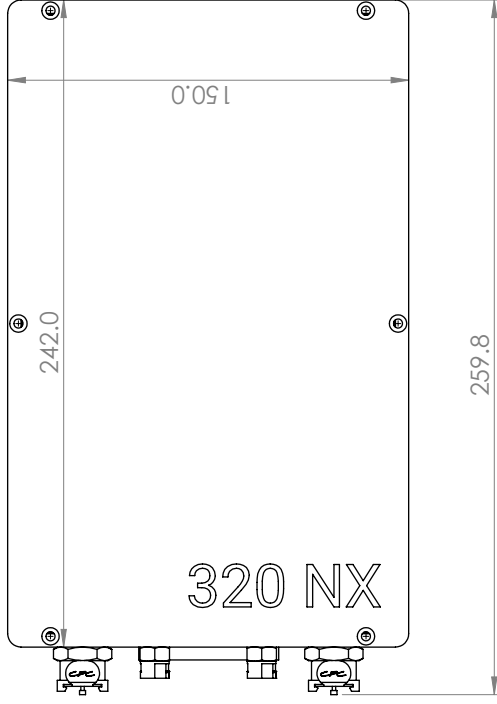

2x 3/8" NPT coupling
(tubing provided)

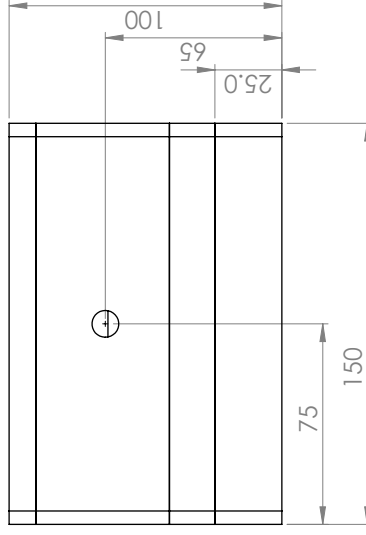
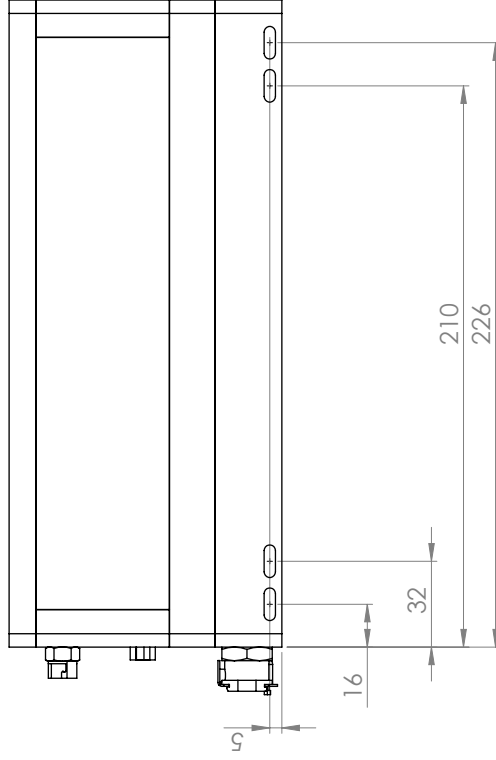
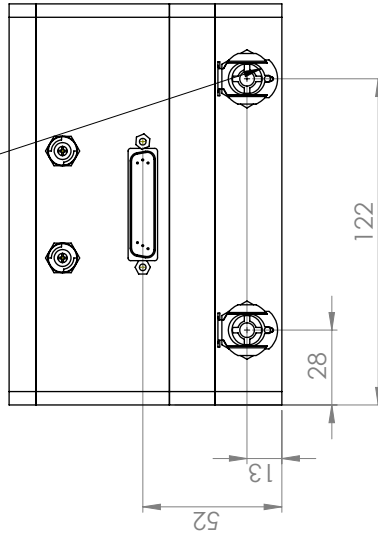

Dimensions in mm
General tolerances: per DIN/ISO 2768-H
Form/Position tolerances: per DIN/ISO 1101
Edges: per DIN/ISO 6784

UnikLasers Ltd Reg Office: 5th Floor, 125 Princess Street Edinburgh, EH1 4AD	SCALE: 1:2 	STOCK NUMBER: 320 NX - 200
	MATERIAL:	DWG NO:
PROJECT:	REVISION: A0	SHEET OF 2

The copyright in this work belongs to UnikLasers Ltd, and the document is issued in confidence for the purposes only for which it is supplied. It should not be copied in whole or in part or used for tendering or manufacturing purposes except under agreement or with written consent of UnikLasers Ltd, and then only on the condition that this notice is repeated in any such copy.