

813.4 QT

Ultra-narrow Linewidth Laser



UniKLasers supplies ultra-narrow linewidth QT Series lasers to our partners in quantum sensing, quantum metrology, and other related technologies, at the specific wavelengths related to the atomic transitions they need to target. Our QT Laser Series includes the 780.24 QT for Rubidium, as well as the 689.4 QT, 698.4 QT and 813.42 QT for Strontium.

KEY FEATURES



Ultra-narrow Linewidth
 ≤ 0.3 MHz



High Power Stability
 ≤ 2.0 % over 8 hours



High Spectral Stability
 ± 1 pm over 8 hours



Excellent Beam Quality



Designed for Strontium Atoms

APPLICATIONS

Quantum Research - Strontium

Specifications

Output Beam Parameters:

Output Power	up to 100 mW*
Wavelength	813.4 nm
Spectral Bandwidth	≤ 0.3 MHz
Spatial Mode	TEM ₀₀
Spectral Stability	± 1.0 pm (over 8 hour operation)
Coherence Length	> 100 m
Output Power Stability	≤ 2.0 % (over 8 hour operation)
Output Power Noise	≤ 0.1 % RMS (10 Hz – 10 MHz)
Beam Divergence	≤ 1 mrad, diffraction limited
Beam Diameter at Output Aperture	0.8 – 1.2 mm
Beam Pointing Stability	≤ 5 μ rad/°C
Polarisation Ratio	$\geq 100:1$, vertical

Integration Features:

Plug-In USB Connectivity	Combined Heatsink
Versatile Control Software	Remote Diagnostic Support

Laser Head Dimensions:

L x W	210 x 100 mm
Beam Height	65 mm

Environmental Conditions:

Ambient Temperature Range	18 – 30 °C
Laser Head Interface Stability	± 1.5 °C
Storage	0 – 50 °C
Humidity	5 – 95 %, non-condensing

Optional Accessories:

Heatsink	Fan-Assisted
	Water-Cooled with Thermoelectric Chiller
External Power Control Module	0 – 100 %, continuous
Tuning Range, mode-hop free	25 – 50 GHz

Low Power Alignment Beam Mode

* Other output powers available on request

Laser and Heatsink Dimensions

210 x 100 x 95 mm

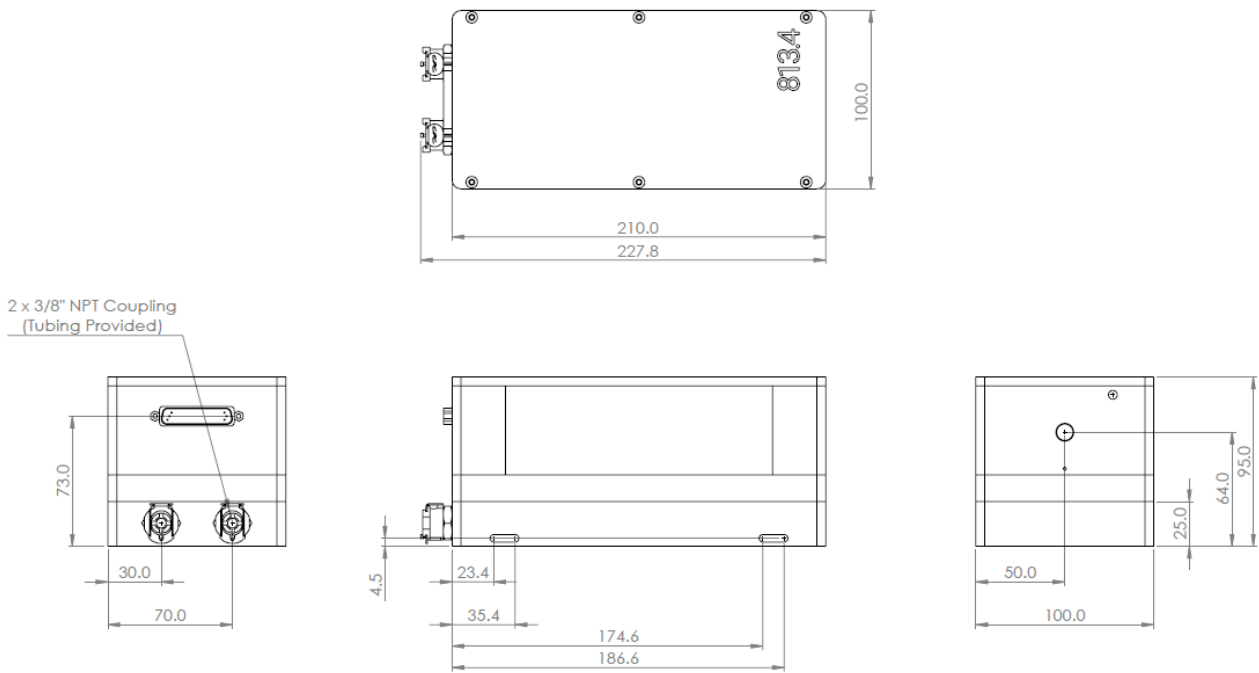

CONTACT US

- ✉ info@uniklasers.com
- ☎ +44 (0)131 333 2200
- 🌐 uniklasers.com

DESIGNED & MANUFACTURED IN THE UK 



AVOID EYE OR SKIN EXPOSURE TO DIRECT OR SCATTERED RADIATION
CLASS 4 LASER PRODUCT
MAX. POWER: 1000 mW
(IEC 60825-1)