

# Becker & Hickl GmbH

## LHB-104 Laser Hub User Manual



**Four ps Diode Lasers in One Case**

**Optical Outputs Combined in One Single-Mode Fibre**

**Compatible with all bh TCSPC and FLIM Systems**

**2020**





Becker & Hickl GmbH  
Nunsdorfer Ring 7-9  
12277 Berlin  
Germany  
Tel. +49 / 30 / 787 56 32  
FAX +49 / 30 / 787 57 34  
<http://www.becker-hickl.com>  
email: [info@becker-hickl.com](mailto:info@becker-hickl.com)

February 2020

This brochure is subject to copyright. However, reproduction of small portions of the material in scientific papers or other non-commercial publications is considered fair use under the copyright law. It is requested that a complete citation be included in the publication. If you require confirmation please feel free to contact Becker & Hickl.

## LHB-104 Laser Hub: User Manual

### General Information

The LHB-104 ‘Laser Hub’ contains up to four bh BDS-SM picosecond-diode lasers [1]. The optical outputs of the individual lasers are combined into one single-mode fibre. The device contains control electronics equivalent to the LSB-C and LSB-C2 Laser Switch boxes. In addition, it contains wavelength-multiplexing electronics, inputs for control signals, and outputs for the synchronisation signals to bh SPC modules [2, 3]. The LHB-104 Laser Hub is shown in Fig. 1.



Fig. 1: LHB-104 Laser Hub

Main applications of the LHB-104 are in fluorescence-lifetime (FLIM) laser-scanning microscopy [2, 6, 7, 8]. Running FLIM on a standard confocal microscope requires the addition of ps-pulsed lasers to the system. However, laser scanning microscopes often have only one input for external lasers. Having only one laser available would restrict the applications to a limited group of fluorophores. Swapping of lasers at the optical input of a scanning system, although basically possible [4, 7], is inconvenient and often not possible without re-alignment. The LHB-104 addresses exactly these applications. By controlling the LHB-104 box from the FLIM computer, lasers of different wavelengths can be selected freely. Moreover, different laser wavelengths can be multiplexed to record FLIM images for different excitation wavelength quasi simultaneously [2]. The LHB-104 also supports simultaneous FLIM / PLIM, a technique introduced by bh in 2013 [2, 5]. Other applications include diffuse optical tomography by NIRS techniques [2], fibre-based lifetime spectroscopy of biological systems [9], and fluorescence-lifetime spectrometers [2].

### Manual Control Elements

Manual control elements of the LHB-104 are shown in Fig. 2. There are a key switch to turn on and off the power supply, switches for the laser repetition rate (common for Laser 1 and 2 and Laser 3 and 4), and potentiometers to adjust the laser power. The actual power (in per cent of the maximum) is shown by LCD displays. For use in laser scanning microscopy the LHB-104 can be equipped with a multiplexing module (MPM). The MPM module receives the scan clock pulses of the microscope and multiplexes two of the available lasers synchronously with the pixels, lines, or frames of the scan. The multiplexing mode is selected by a switch below the laser power indicators.

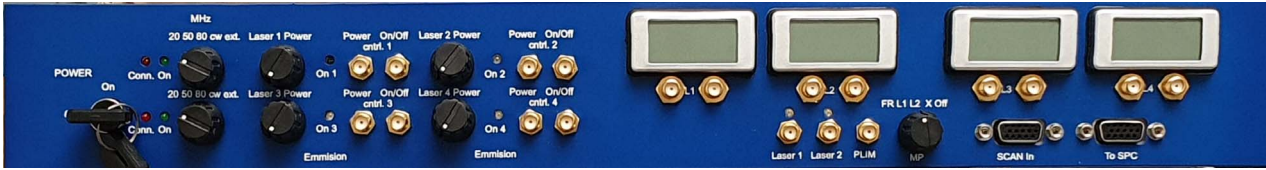

Fig. 2: Control elements and connectors at the LHB-104 front panel

## Signal Inputs and Outputs at the Front Panel

There are inputs for analog control of the laser power (0...+10 V), inputs for a digital laser on/off signal, inputs for external synchronisation signals (CMOS), and outputs for the Sync signals to bh TCSPC / FLIM modules. Devices with a multiplexing module have also two outputs for multiplexing signals and an input for a PLIM modulation signal from a DDG-210 pulse generator. Please see Fig. 2. For signal description please see page 7.

## Manual Control of Lasers

### Frequency Switch, Lasers 1 and 2

20, 50, 80 MHz      Repetition rate of lasers 1 and 2. BDS-SMY yellow and green lasers have only 20 MHz and 50 MHz.  
 CW                      CW operation of lasers. BDS-SMY yellow and green lasers have no CW mode.  
 Ext.                      External control of repetition rate or CW operation via connectors at the rear panel, Laser 1 and Laser 2 Ext. Ctrl.

### Frequency Switch, Lasers 3 and 4

20, 50, 80 MHz      Repetition rate of lasers 1 and 2. BDS-SMY yellow and green lasers have only 20 MHz and 50 MHz.  
 CW                      CW operation of lasers. BDS-SMY yellow and green lasers have no CW mode.  
 Ext.                      External control of repetition rate or CW operation via connectors at the rear panel, Laser 3 and Laser 4 Ext. Ctrl.

Laser 1,2,3,4 Power      Potentiometers for manual control of laser power. Power in % of maximum is displayed by the LCDs on the right of the front panel. Connection of an analog signal of 0..10 V with low source impedance to the power control connectors at the front panel or to the power control pins of the 15-pin sub-D connectors at the rear panel overwrites manual power control.

## Operation via the DCC-100 Detector/Laser Controller

Laser control from the bh DCC-100 (Fig. 3, left) is performed via the signals at the three 15 pin sub-D interface connectors. One DCC module generates the power control voltages and the digital (on/off) control signals for two lasers. For four lasers two DCC modules are required. For lasers with variable optical attenuators the DCC also controls the motors of the ND filter wheels. DCC connectors 1 and 3 deliver the power control signal, connector 2 delivers the Laser On/Off and the motor signals. The connection of the DCC card to the LHB requires a special cable that distributes the DCC output signals to the correct inputs of the LHB. The cable is available from bh. For cable definition please see page 6.

The DCC software panel for control of two lasers is shown in Fig. 3, right. The driving power for the laser diode of laser 1 and laser 2 is controlled by the sliders under 'Laser 1' and 'Laser 2'. The buttons in the middle (marked L1 OFF and L2 OFF) turn the lasers on and off. The buttons L1 UP or L1 DWN

and L2 UP and L2 DWN increase or decrease the optical power via the optical attenuator wheels. For software-panel configuration please see [2], [6], or [7].

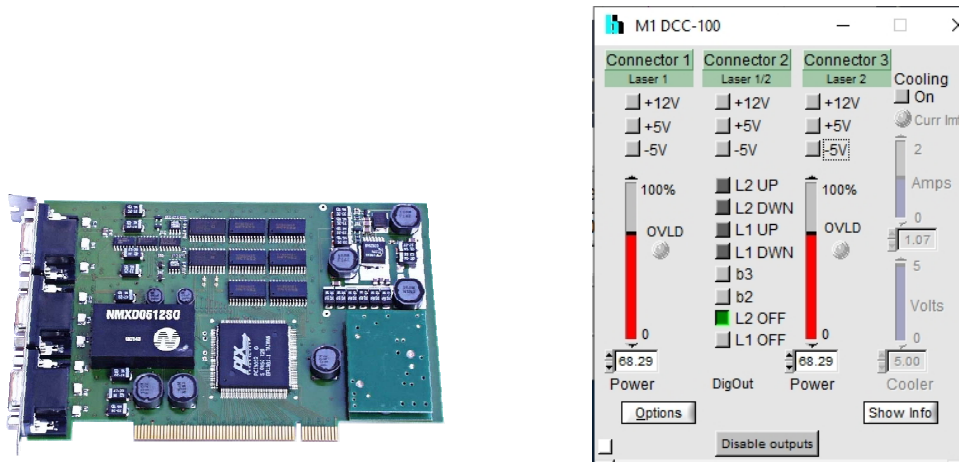

Fig. 3: Left: DCC-100 module. Right: DCC-100 software panel, configured for control of two lasers

### Operation via the DCU-400 or DCU-800 Detector/Laser Controller

The DCU-400 is a detector/laser controller with outputs to four individual lasers or detectors. It is connected to the TCSPC system computer via a USB interface. The device is shown in Fig. 4, left and middle. The software panel for control of two lasers and two detectors is shown in Fig. 4, right. The (electrical) laser power is controlled via the two sliders on the left. The gain of the detectors is controlled by the right two sliders. Laser emission is turned on and off and the optical intensity pulled up and down by the buttons under ‘Laser 1/2’ on the right.



Fig. 4: Left and middle: DCU-400 detector/laser controller. Right: DCU software panel for control of two lasers and two detectors.

Control of four lasers and two detectors is shown in Fig. 5. The setup requires two DCU-400 (4 output channels each) or one DCU-800 module (8 output channels). The electrical power of the four lasers is controlled by the four sliders on the left, the gain of the detectors by the two sliders in the middle. Two outputs are left unused. They can be used for additional detectors or other control tasks within the TCSPC system. The Laser on/off buttons and the attenuator buttons are located in the middle (Laser 1, 2) and on the right (Laser 3, 4).

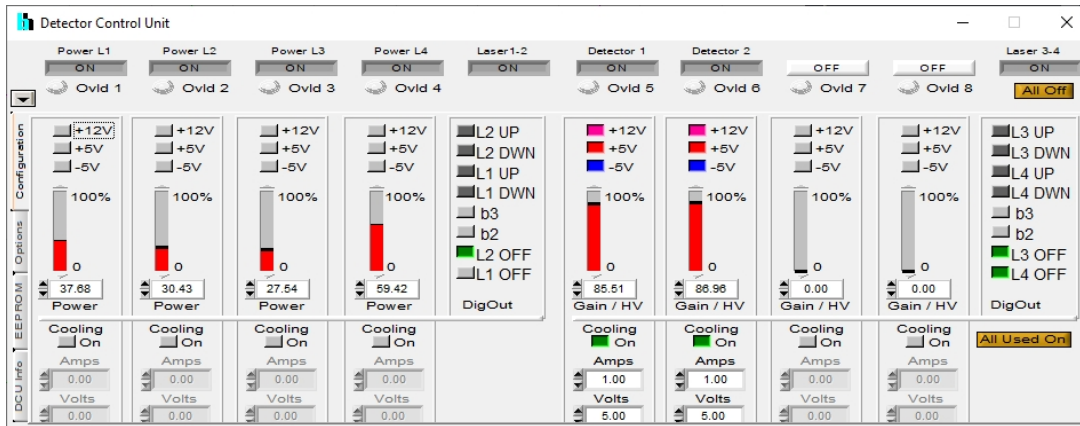

Fig. 5: Control of four lasers and two detectors

## Using the Multiplexing Module

The multiplexing module (MPM) can be used to multiplex two of the available lasers, simultaneously recording several FLIM images for different excitation and emission wavelength. The principle is described in [2, 3]. To multiplex lasers, turn the multiplexing switch to either Frame, Line, or PXL, see Fig. 6, left. Connect the outputs of the MPM to the ‘Laser ON’ inputs for the two lasers to be multiplexed (Fig. 6, middle). In the DCC or DCU panel, turn on the lasers which are to be multiplexed, see Fig. 6, right. The MPM multiplexes the lasers synchronously with the pixels, lines, or frames of the scan. To do so, it needs the scan clocks from the laser scanning microscope. Therefore, make sure that the scan clocks from the microscope to the TCSPC system are fed through the MPM, as shown in Fig. 7.



Fig. 6: Left: MPM mode switch. Middle: Cables from MPM to Laser ON inputs, lasers 3 and 4 are multiplexed by MPM outputs 1 and 2. Right: DCU panel with lasers 1 and 2 turned on



Fig. 7: Connection of the Scan clock signals through the MPM module. 'SCAN In' is the input from the scan controller, 'To SPC' is the output to the TCSPC module(s)

## Control Cables

Cables to connect the DCC or DCU with the LHB are available from bh. The cables have three connectors at the DCC / DCU side and two connectors at the LHB side, see Fig. 8. One cable connects

the signals for two lasers. The same cables can be used to control lasers via the LSB-C and LSB-C2 laser switch boxes [1]. The pin assignment is shown in Fig. 9.

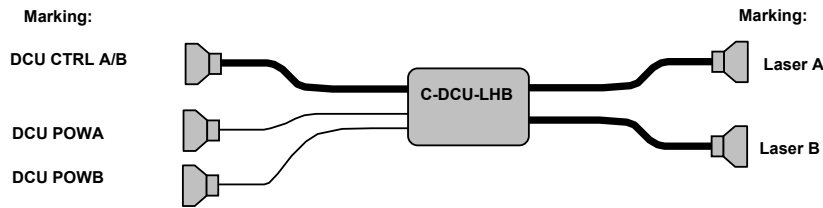

Fig. 8: DCU-LHB connection cable

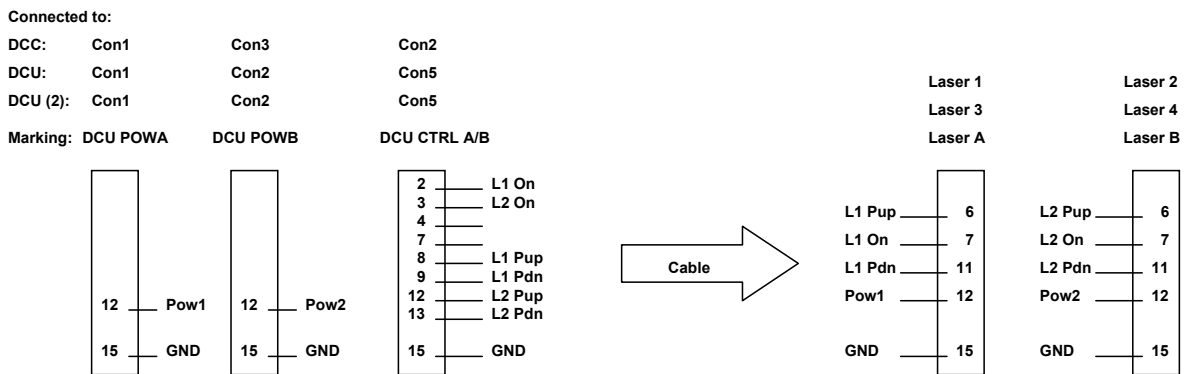

Fig. 9: Pin assignment of DCU - LHB cables

## Description of Input and Output Signals

### SMA connectors at the front panel

#### Power Ctrl. 1 and 2

Analog inputs for power control, lasers 1 and 2. Voltage is 0 to 10 V. Optical power is proportional to voltage. Input overwrites manual power control if source impedance is  $< 100 \Omega$ , see connection diagram below. Inputs are connected in parallel with pin 12 of sub-D connectors for external-control of lasers 1 and 2.

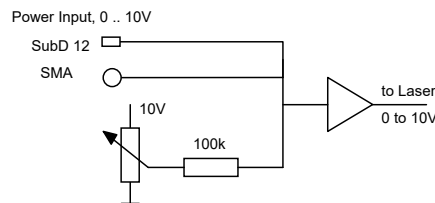

#### Power Ctrl. 3 and 4

Analog input for power control, lasers 3 and 4. Voltage is 0 to 10 V. Optical power is proportional to voltage. Input overwrites manual power control if source impedance is  $< 100 \Omega$ . Inputs are connected in parallel with pin 12 of sub-D connectors for external-control of lasers 3 and 4. Power inputs 3 and 4 are not available for LHBs with 2 lasers.

#### On/Off Ctrl. 1 and 2

TTL/CMOS input. Switches laser emission on and off. L level turns emission off, H level turns emission on. The inputs have internal pull-up resistors. That means emission is on when inputs are left open, emission is off when inputs connected to GND. Inputs are connected in parallel with pin 7 of sub-D connectors for external-control of lasers 1 and 2. Response time



## LHB-104 Laser Hub

is <500 ns at >20% laser power. It can increase to about 4  $\mu$ s at low laser power [1].

On/Off Ctrl. 3 and 4	TTL/CMOS input. Switches laser emission on and off. L level turns emission off, H level turns emission on. The inputs have internal pull-up resistors. That means emission is on when inputs are left open, emission is off when inputs connected to GND. Inputs are connected in parallel with pin 7 of sub-D connectors for external-control of lasers 3 and 4. Response time is <500 ns at >20% laser power. It can increase to about 4 $\mu$ s at low laser power [1]. On/Off inputs 3 and 4 are not available for LHBs with 2 lasers.
SYNC Out (L1..4, right)	Synchronisation outputs to the TCSPC system. Separate for the individual lasers. Amplitude about -1.5 V, pulse width about 2 ns, see [1].
SYNC In (L1..4, left)	Inputs for synchronisation of the lasers to external TTL/CMOS signals. Application of a signal with less than 40 % duty cycle disables the internal clock generator of the laser and switches the laser clock to the external signal. Frequency should be within $\pm 20$ % of the frequency selected by the frequency selection switch. For frequencies outside this range the internal intensity regulation loop of the laser can saturate, resulting in unexpectedly low or high pulse power with unfavourable optical pulse shape. Connecting the SYNC input to GND suppresses laser pulsing in the ps-pulsed mode. It does not suppress emission in the CW mode.
Laser 1 Multiplex	Output for Laser ON from the multiplexing module. When multiplexing is enabled by the multiplexing mode switch the output is H within the first half and L in the second half of the multiplexing period. Output is H when multiplexing is disabled. Connect to Laser ON input of the first laser of a pair of multiplexed lasers. Output goes to L (laser off) for beam flyback if the beam blanking function is used. Output goes to L (laser off) when the PLIM input is pulled to L state. Available only for LHBs with multiplexing module.
Laser 2 Multiplex	Output for Laser ON from the multiplexing module. When multiplexing is enabled by the multiplexing mode switch the output is L within the first half and H in the second half of the multiplexing period. Output is H when multiplexing is disabled. Connect to Laser ON input of the second laser of a pair of multiplexed lasers. Output goes to L (laser off) for beam flyback if the beam blanking function is used. Output goes to L (laser off) when the PLIM input is pulled to L state. Available only for LHBs with multiplexing module.
PLIM	ON/OFF modulation for both connected lasers in the PLIM or combined FLIM/PLIM mode of a bh FLIM system. Emission from the connected lasers is turned off when the PLIM signal is in the L state.

### Sub-D Connectors at the Front Panel

SCAN In	Input for scan clock signals from laser scanning microscopes or other optical scanners. Scan clocks are passed to the TCSPC system via the 'SCAN to SPC' connector. In the MPM module the signals control the laser multiplexing.
---------	---

1 +5 V from TCSPC system



- 2 Routing signal R0, for operation with bh GVD-120 scan controller only
- 3 Laser 1 ON, for operation with bh GVD-120 scan controller only
- 4 Laser 2 ON, for operation with bh GVD-120 scan controller only
- 5 GND
- 6 not used
- 7 not used
- 8 Frame Clock
- 9 Line Clock
- 10 Power laser 1, for operation with bh GVD-120 scan controller only
- 11 Beam blanking or Power laser 1, from bh GVD-120 scan controller
- 12 Pixel Clock
- 13 Trigger to TCSPC system (Experiment Trigger)
- 14 Not used
- 15 GND

SCAN to SPC

Output of scan clocks and control signals to TCSPC system

- 1 +5 V from TCSPC system
- 2 Routing signal R0, from multiplexing module or bh GVD-120 scan controller
- 3 Laser 1 ON, only when operated with bh GVD-120 scan controller only
- 4 Laser 2 ON, only when operated with bh GVD-120 scan controller only
- 5 GND
- 6 not used
- 7 not used
- 8 Frame Clock
- 9 Line Clock
- 10 Power laser 1, only when operated with bh GVD-120 scan controller
- 11 Beam blanking or power laser 1 (when operated from GVD-120 scan controller)
- 12 Pixel clock
- 13 Trigger
- 14 not used
- 15 GND

**Sub-D Connectors at the Rear Panel**

Laser 1...4 Ext Ctrl      Power, Laser On, and Frequency control signals to lasers. Control lines to motors for variable attenuator wheels.

- 1 not connected
- 2 Frequency 1 (20 MHz)
- 3 Frequency 2 (50 MHz)
- 4 Frequency 3 (80 MHz, not effective for BDL-SMY lasers)
- 5 GND
- 6 To motor for attenuator wheel. Pull to GND for 'Power UP'.
- 7 Laser ON
- 8 CW operation. Not effective for BDL-SMY lasers
- 9 not connected
- 10 not connected
- 11 To motor for attenuator wheel. Pull to GND for 'Power Down'.
- 12 Laser power, 0...+10 V
- 13 not connected
- 14 not connected
- 15 GND

Power +12 V DC

Power supply connector, 9 pin. Absolute maximum voltage is +15 V.

- 1, 2, 6 +12V
- 4,5,8,9 GND

Use only power the supply delivered with the LHB-104. Especially, do not use power supplies which have no guard electrode. Noise voltage injected by these power supplies can cause electrical damage when external devices are connected to the LHB-104 or even cause mild electrical shock. Power supply current is between 1.3 A and 1.8 A for devices with four lasers. During power ramp up the inrush current can be up to 3 A.

## Laser Safety

### General Instructions

The LHB-104 is a class 3B laser product. The laser class is indicated on the laser by an ‘explanatory label’, Fig. 10, left. The laser aperture is marked with the aperture labels, Fig. 10, second left and second right. Each laser hub has a manufacturer identification, as shown in Fig. 10, right. The location of the labels on the LHB-104 is shown in Fig. 11.



Fig. 10. Left to right: Explanatory label, aperture labels.



Fig. 11: LHB-104 with laser safety labels

Laser safety regulations forbid the user to open the housing of the laser, or to do any maintenance or service operations at or inside the Laser Hub. Use of controls or adjustments or performance of procedures other than specified in this manual can result in hazardous radiation exposure or damage to the laser module.

Some of the fibre-output versions emit a collimated beam from the end of the fibre. Do not look into the collimated beam. Do not look into an un-collimated beam through lenses, binoculars, microscopes, camera finders, telescopes, or other optical elements that may collimate the light into your eye. Wear eye protection when working at the open laser beam path. Make sure the eye protection covers the entire range of laser wavelengths delivered by the LHB-104. When using the lasers in combination with a microscope make sure that the beam path to the eyepieces is blocked when the laser is on.

### Laser Safety Interlock

The LHB-104 has two laser-safety interlock inputs. Either the Interlock Negative (ILN) input must be connected to Ground or the Interlock Positive (ILP) input must be connected to +5 V or +12 V to enable laser function, see Fig. 12. The inputs act on the power supply of all laser. In the 'Disable' state the power to all lasers connected to the devices is switched off. Input current is -0.1 mA for the ILN

pin and +0.1 mA for the ILP pin. The interlock signal connector is located at the back panel of the LHB. A laser interlock cable is delivered with the LHB-104 devices, see Fig. 13.

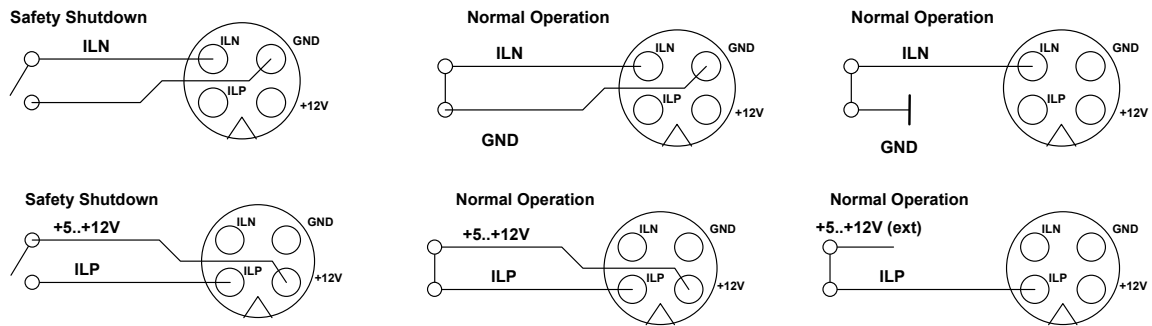

Fig. 12: Interlock Signal connections

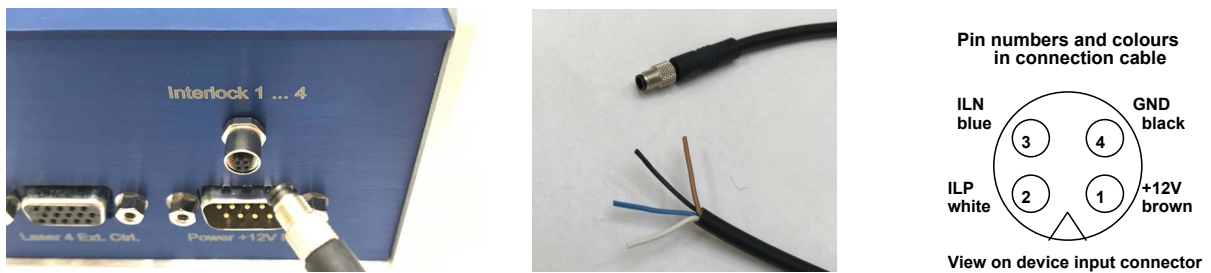

Fig. 13: Laser-safety interlock. Left: Interlock connector at LHB-104 rear panel. Middle: Safety interlock cable. Right: Pin assignment of safety-interlock connector.

## References

1. BDS-SM Family Picosecond Diode Lasers. Extended data sheet, [www.becker-hickl.com](http://www.becker-hickl.com)
2. W. Becker, The bh TCSPC handbook. 8th edition. Becker & Hickl GmbH (2019), [www.becker-hickl.com](http://www.becker-hickl.com), printed copies available from bh
3. W. Becker, The bh TCSPC Technique, Principles and Applications. Available on [www.becker-hickl.com](http://www.becker-hickl.com).
4. Becker & Hickl GmbH, DCS-120 Confocal FLIM system with wideband beamsplitter. Application note, available on [www.becker-hickl.com](http://www.becker-hickl.com)
5. Becker & Hickl GmbH, Simultaneous Phosphorescence and Fluorescence Lifetime Imaging by Multi-Dimensional TCSPC and Multi-Pulse Excitation. Application note, available on [www.becker-hickl.com](http://www.becker-hickl.com)
6. Becker & Hickl GmbH, Modular FLIM systems for Zeiss LSM 710 / 780 / 880 family laser scanning microscopes. User handbook, 7th ed. (2017). Available on [www.becker-hickl.com](http://www.becker-hickl.com)
7. Becker & Hickl GmbH, DCS-120 Confocal and Multiphoton FLIM Systems, user handbook 8th ed. (2019). Available on [www.becker-hickl.com](http://www.becker-hickl.com)
8. FLIM Systems for Laser Scanning Microscopes. Overview brochure (2019). Available on [www.becker-hickl.com](http://www.becker-hickl.com)
9. TCSPC Fibre-Probe System with an Exchangeable Tip. Application note, available on [www.becker-hickl.com](http://www.becker-hickl.com)



Becker & Hickl GmbH  
Nunsdorfer Ring 7-9  
12277 Berlin  
Germany  
Tel. +49 / 30 / 212 800 20  
FAX +49 / 30 / 212 800 213  
<http://www.becker-hickl.com>  
email: [info@becker-hickl.com](mailto:info@becker-hickl.com)