

Lu130 & Lu135

1.4 Megapixel USB 2.0 Camera



High Image Quality in Low Light Conditions

Lumenera's Lu130 and Lu135 series of megapixel cameras are designed to be used in a wide variety of industrial applications, particularly in low light conditions. With 1392 x 1040 resolution and on-board processing these cameras deliver outstanding image quality and value for industrial and scientific imaging applications.

Capture Objects in High Speed Motion

Electronic Global Shutter provides capabilities similar to a mechanical shutter, allowing simultaneous integration of the entire pixel array, and then stopping exposure while image data is read out. Ideal for capturing objects in high-speed motion.

Live Stream and Still Image Capturing

Uncompressed images in live streaming video and still image capture are provided across a USB 2.0 digital interface. No framegrabber is required. Advanced camera control is available through a complete Software Developer's Kit, with sample code available to quickly integrate camera functions into OEM applications.

Customizable Form Factors

Hardware and software based synchronization trigger is provided standard. Camera models are offered in both enclosed (Lu130) and board-level (Lu135) form. Custom form factor (sizes) as well as color and monochrome camera models are available.

Application

The Lumenera Camera SDK provides a full suite of features and functions that allow you to maximize the performance of your camera within your application. The SDK is compatible with all USB and GigE based cameras. Microsoft DirectX/DirectShow, Windows API and .NET API interfaces are provided allowing you the choice of application development environments from C/C++ to VB.NET or C#.NET. Full inline IntelliSense autocompletion and documentation is provided with the .NET API interface and is accompanied by a full API manual describing all the camera functions and properties.

Features

- High quality Sony HAD ICX205AK sensor
- Excellent sensitivity with high color reproductivity
- Color or monochrome, interline transfer progressive scan, 1.4 megapixel CCD sensor
- 15 fps at full 1392 x 1040 resolution
30 fps at 640 x 480
- Binning and Region of Interest (ROI) options improve sensitivity and provide higher frame rates
- Global shutter for capturing fast moving objects and strobe lighting
- GPIOs for control of peripherals and synchronization of lighting (4in/4out)
- FCC Class B, CE Ready
- RGB Bayer video output
- Select 8 or 12-bit pixel data
- Simplified cabling - video and full camera control over a single USB cable
- C-mount provided
- DirectShow compatible
- Software compatible with Windows 10, Windows 8.1, Windows 7, Linux, 32 and 64-bit operating systems
- Complete SDK available
- Four (4) year warranty



Color Quantum Efficiency Curves

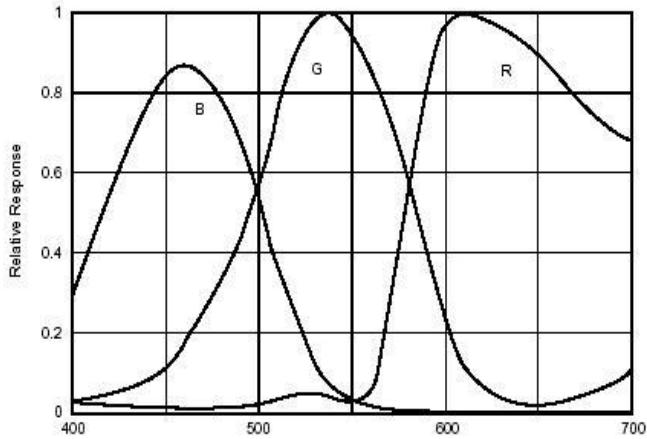

Monochrome Quantum Efficiency Curve

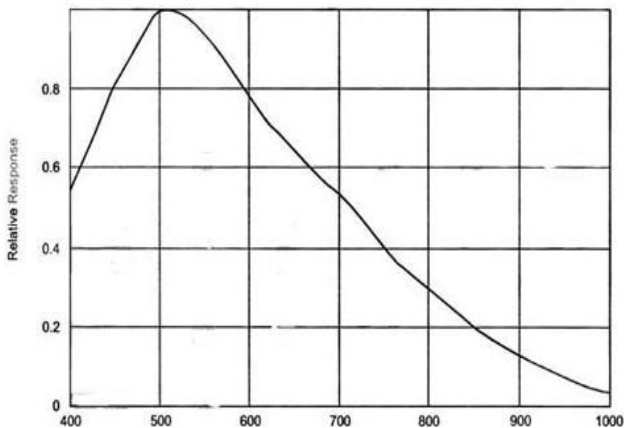

Ordering Options	
Lu130M	1.4 Megapixel Monochrome Module (Board Level)
Lu130C	1.4 Megapixel Color Camera Module (Board Level)
Lu135M	1.4 Megapixel Enclosed Monochrome Camera
Lu135C	1.4 Megapixel Enclosed Color Camera
LuSDK	Software Developer's Kit (Web download)
La050315	Transformer, 5VDC, 15W, 3A, International
Camera Includes	
Lu802	2M USB 2.0 A to B cable
Customization Options	
-WOIR	Without IR Cut Filter (in optical path)
-WOCG	Color cover glass remove
-CS	With Adjustable CS-mount lens mount
-IO access	Color

Sensor Specifications	
Image Sensor	Sony HAD ICX205AK, CCD, color or mono, progressive scan
Optical Format	1/2"
Imager Size	Diagonal 8.00 mm
Pixel Size	4.65 x 4.65 μ m
Resolution	1392 x 1040 pixels
Camera Specifications	
Frame Rate	15 fps @ 1392x1040, 30 fps @ 640x480
Bit Depth	8 or 12-bits
Binning Modes	2 x 2 and 4 x 4
Exposure Control	Manual
Exposure Range	63 μ s to 2.0 ms (video), 0 to 300 seconds (snapshot)
Gain Control	Manual
Gain Range	1 to 23.82 X
White Balance	Manual
Camera Characteristics	
Dynamic Range	60 dB
Full Well Capacity	10,000 e-
Read Noise	8 e-
Dark Current Noise	<0.01 e-/s @20 °C
Mechanical Specifications	
Data Interface	Standard USB cable
Lens Mount	Adjustable C-mount standard, (CS-mount option)
Dimensions (HxWxD)	39.62 x 57.15 x 96.52 mm (enclosed) 1.56 x 2.25 x 3.8 inch (enclosed)
Mass	300 g (enclosed)
Operating Temperature	0 to 50 °C
Storage Temperature	-30 to 70 °C
Operating Humidity	5 to 95 %, non condensing
Shock / Vibration	50 g shock, 5 g (2 to 200 Hz) vibration
Onboard Memory	Camera has onboard non-volatile memory storage
Camera Software	
Operating Systems	Windows 10, Windows 8.1, Windows 7, Linux, 32 and 64-bit operating systems
Software Interfaces	Windows API, .NET, DirectX
Power and Emissions	
Power Consumption	~2.5 W
Power Requirement	USB bus power, or external 6 V DC, 700 mA
Emissions Compliances	FCC Class BE, CE Certified
Hazardous Materials	RoHS, WEEE Compliant
Warranty	Four (4) year
System Requirements	
Recommended PC Specs	<ul style="list-style-type: none"> • Pentium 4, 1.3 GHz or higher • 512 MB RAM • 60 MB hard drive free space or more • USB 2.0 Port • Windows 10, 8.1, 7; Linux



Enclosed Mechanical Drawings

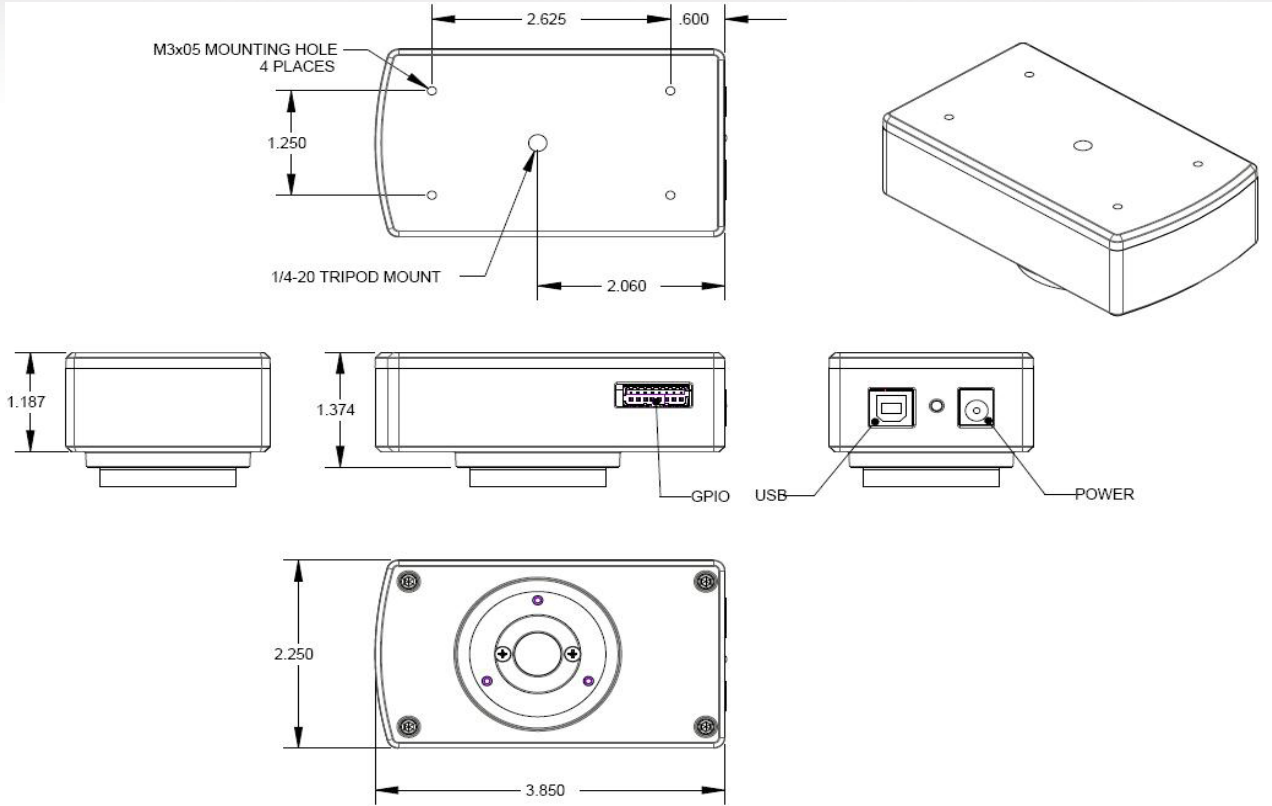

Board Level Mechanical Drawings

