



PyLoN: 2048 2048 x 2048

The PyLoN: 2048 is a controllerless, cryogenically-cooled CCD camera designed for quantitative scientific imaging applications demanding the highest possible sensitivity. Princeton Instruments has completely redesigned the industry-leading VersArray: 2048/LN camera to eliminate the external controller, increasing experimental flexibility while further improving the ultralow noise electronics. Liquid nitrogen cooling virtually eliminates dark current. PyLoN features ADC rates from **50 KHz to 4 MHz**, with digital bias stabilization and correlated double sampling for decreased read noise and improved linearity. Additionally, Princeton Instruments' exclusive eXcelon® technology delivers the highest responsivity from the UV to the NIR while suppressing etaloning that occurs in standard back-illuminated CCDs.

FEATURE	BENEFITS
eXcelon technology	Increases detector sensitivity while suppressing etalon interference fringes observed in the NIR with conventional back-illuminated devices.
2048 x 2048 imaging array, 13.5 μm x 13.5 μm pixels	e2v CCD 42-40 with 27.65 x 27.65 mm large field of view; 13.5 μm pixel size offers the optimal combination of high resolution and dynamic range.
Cryogenic cooling to -120°C, using liquid nitrogen	Effectively eliminates dark charge, permitting acquisition times from milliseconds to hours.
Single fused silica vacuum window	Minimizes reflection losses from UV to IR; Optional AR coatings & wedge windows are available.
Optional UV phosphor coatings	Extends CCD sensitivity to below 200 nm.
TTL input and output	Allows external control of and triggering by lasers and other devices.
Dual sensitivity amplifier with software-selectable system gains	High sensitivity amplifier reduces read noise floor for weak signals; High capacity amplifier increases dynamic range.
Kinetics & Custom Sensor modes	Standard on all PyLoN cameras, Kinetics mode allows microsecond-resolved kinetic spectral acquisition, while Custom Sensor mode increases control over the camera readout.
Data acquisition rates of 50 kHz to 4 MHz	Use low speed for lowest system noise, high speed for rapid image acquisition.
Optional end-on and all-directional dewar mounts	Allows for easy and flexible camera positioning.
GigE data interface	Reliable data transmission over 50 m for remote operation.
Optional: LightField® (for Windows 8/7, 64-bit) Or WinView/Spec (for Windows 8/7/XP, 32-bit)	Flexible software packages for data acquisition, display and analysis; LightField offers intuitive, cutting edge user interface, IntelliCal® and more.
PICAM (64-bit) / PVCAM (32-bit) software development kits (SDKs)	Compatible with Windows 8/7/XP, and Linux; Universal programming interfaces for easy custom programming.

Applications:
Astronomy, Chemiluminescence,
Bioluminescence, Phosphor Imaging,
Ultra-low light Imaging and Spectroscopy

	PyLoN: 2048BR		PyLoN: 2048B_eXcelon		PyLoN: 2048B		PyLoN: 2048F	
Features	Back-illuminated, deep depletion CCD. High QE in the NIR with minimal etaloning.		Back-illuminated CCD with eXcelon technology. Enhanced QE in the UV and the NIR with low etaloning.		Back-illuminated CCD. Highest QE in the visible with low dark current. Subject to etaloning in the NIR.		Front-illuminated CCD. Affordable technology for moderate light level applications. No etaloning.	
Typical dark current @ -120°C (e ⁻ /pixel/hour) *	0.1		0.1		0.1		0.1	
Readout Speed	50 KHz	100 KHz	200 KHz	500 KHz	1 MHz	2 MHz	4 MHz	
Typical Noise** (e ⁻)	4.0	4.5	6.0	7.0	9.0	20.0	28.0	
Operating temperature	-70°C to -120°C with ±0.05°C thermostating precision							
CCD format	2048 x 2048, 13.5 μm x 13.5 μm pixels with 100% fill factor							
Imaging area	27.65 x 27.65 mm (optically centered)							
Well capacity:								
Pixel Well	100 ke ⁻ (typical), 80 ke ⁻ (min)							
Output Node	250 ke ⁻ (typical), 200 ke ⁻ (min)							
ADC rates	50, 100, 200, 500 kHz and 1, 2, 4 MHz; 16 bits							
Non-linearity	< 1% @ 100 kHz							
Vertical shift times	32 μsec/row (programmable)							
Analog gain (typical)	1, 2, 4 e ⁻ /ADU (high sensitivity); 3, 6, 12 e ⁻ /ADU (high capacity)							
Data interface	Gigabit Ethernet							
I/O signals	Trigger In, TTL Out, Readout Monitor, Expose Monitor, Shutter Monitor							
Optical mount	Princeton Instruments' Acton spectrometer adapter with optional 40 mm shutter							
Operating environment	+5°C to +30°C, non-condensing atmosphere							
Certification	CE							
Dimensions	14.6 inches (371 mm) x 8.2 inches (208 mm) x 10.5 inches (267 mm) (H x W x D)							
Weight	Approximately 10 lbs (4.5 kg)							

* Limited by cosmic ray background

** High sensitivity amplifier

All specifications are subject to change

READOUT TIME

Binning	@ 4 MHz
1 x 1	1.08 s
2 x 2	288 ms
4 x 4	90.25 ms
8 x 8	41.02 ms

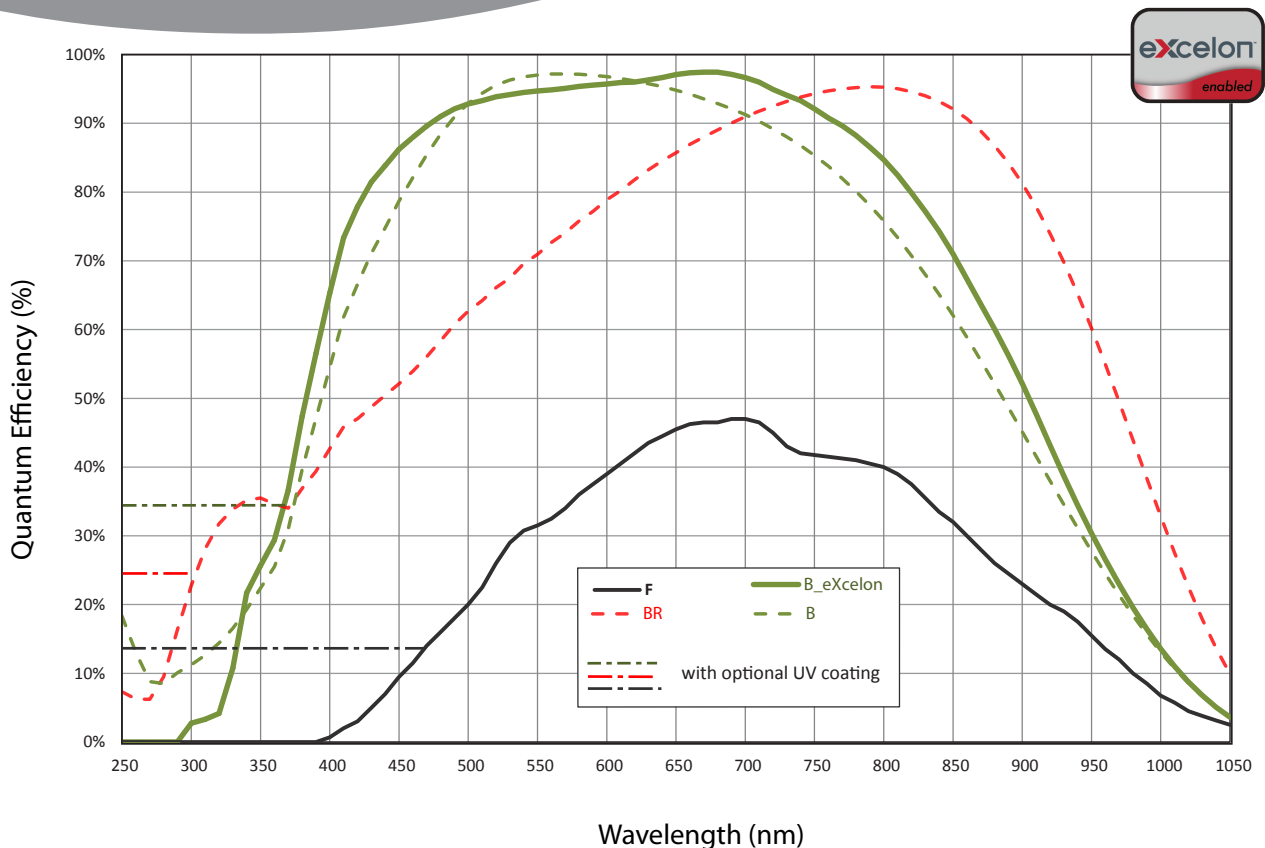

NOTE:

Graph shows typical Quantum Efficiency (QE) data measured at + 25°C. QE decreases at normal operating temperatures. For the best results for your application, please discuss the specific parameters of your experiment with your sales representative.

VACUUM WINDOW AR COATINGS

NOTE:

Standard anti-reflection (AR) coatings shown. Custom AR coatings and wedge window options are also available. Contact your local sales representative for more information.

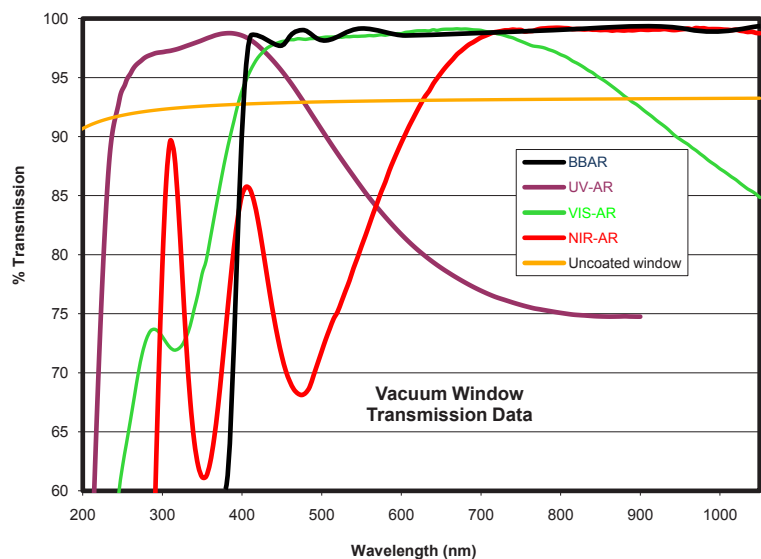

Data taken with white light source through a monochromator, comparing etaloning performance of eXcelon vs. back-illuminated CCDs.

Back-illuminated



Back-illuminated_eXcelon

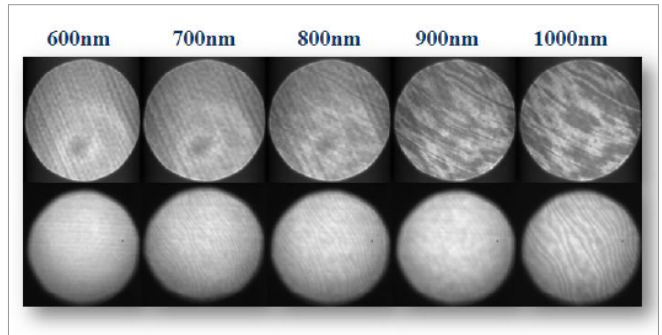

QE Improvement (B_eXcelon vs. B)

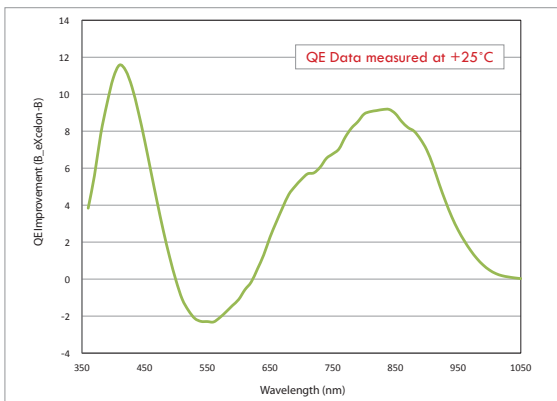

B_eXcelon provides superior QE over the standard back illuminated ("B") version in the UV-NIR range.

Etalon Oscillations (B_eXcelon vs. B)

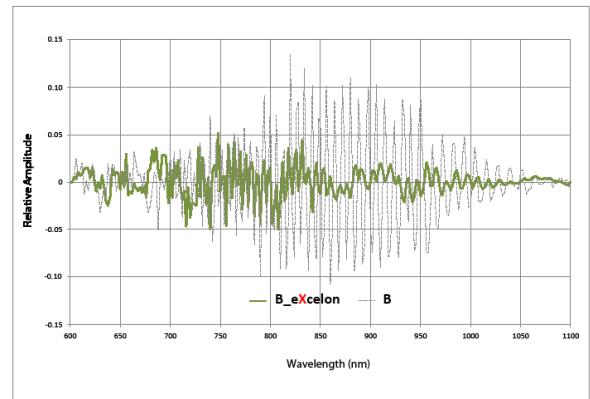

B_eXcelon provides significantly lower etaloning (unwanted fringes) compared to standard back illuminated ("B") version.

PyLoN with 40 mm shutter

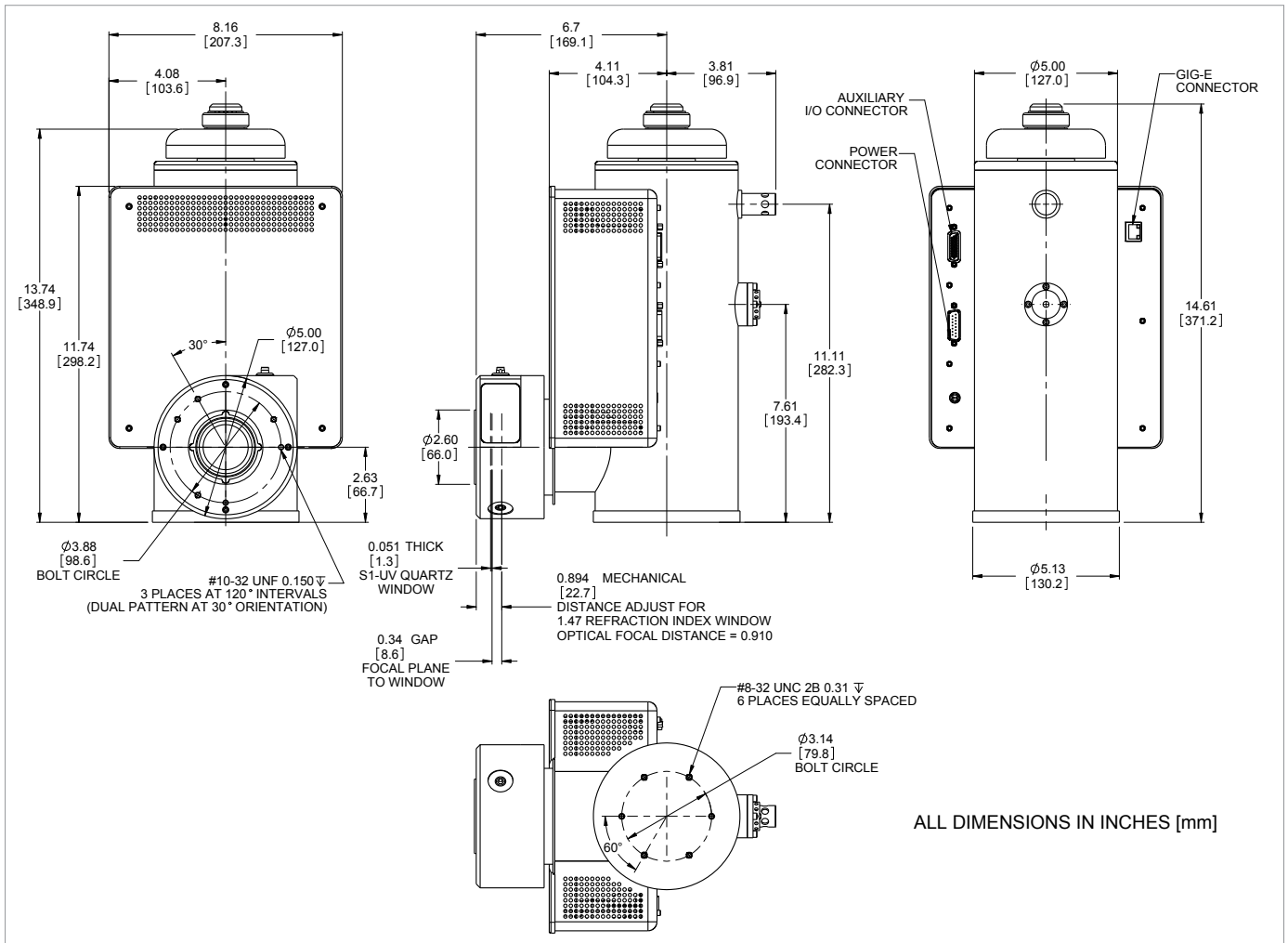

PyLoN without shutter

